

M-Series (Magnetic Drive Gear Pumps)

MODELS 2232H-M05C49/C50/C51

2232H-M05C49/C50/C51

Made in the USA

DESCRIPTION

Flight Works M-Series (Magnetic Drive) Gear Pumps offer the highest level of quality, reliability and versatility in the Flight Works product catalog. The 2232H-M05C49/C50/C51 models use precision-machined parts, magnetic coupling mechanics, and a high-end coreless brushed motor to produce exceptional performance with the highest possible operating life and reliability. The Swiss-made motor allows for simple control, with minimal power draw, while the tight tolerances of both the driving and driven pump components raise performance to optimal levels.



STANDARD SPECIFICATIONS

Diff. Pressure (Max)	450 psid (fluid dependent; see data charts)
Max Flow Rate	925 mL/min
Weight	210 grams
Fluid Temp.	-30 to 100 °C (-22 to 212 °F)
Port Size(s)	See Configuration Options
Std. Voltages	12 V (C49), 24 V (C50), 48 V (C51)
Permissible Fluids (Configuration Specific)	Alcohols, Water, Light Fuels/Oils, Glycol Solutions, Hydraulic Fluids, etc.
Control Options (requires controller)	Open-Loop Control (Voltage) Closed-Loop Control (RPM/Current)

APPLICATIONS

All Flight Works micro gear pumps feature a level of versatility and customization that allows for use in a wide field of applications, including:

- Aerospace
- Instrumentation
- Medical & Laboratory
- Hydraulics
- Cooling
- Food/Beverage/Pharmaceutical
- Fuel Cells

▲ IMPORTANT

This pump is designed to run with an inlet filter (10-50 microns recommended). It may be possible to operate the pump outside of these design limits in certain applications, but this must be checked and validated by the customer.

Specifications and data in this document are for informational purposes only, may vary depending on the system in which the pump is integrated, and are subject to change without notice. Flight Works, Inc. makes no warranties concerning the suitability of this pump for a particular application; as such, it is the customer's responsibility to determine the safety and technical suitability of the system. Refer to the Pump User Guide for more details on handling, setup, operation, and more. This pump is a precision unit, built and assembled as a complete product. Opening, adjusting, or dropping the pump can permanently damage assembly integrity. Please contact Flight Works, Inc. by phone or email with any further questions regarding this product or its function.

CONFIGURATION OPTIONS

WETTED MATERIALS

-O & -H*	-W*	CUSTOM
<ul style="list-style-type: none"> • Hard-Anodized Aluminum • 52100 Alloy Steel • 300- & 400-Series, & 17-4 PH SS • 932 Bearing Bronze • Viton® • Samarium Cobalt • Loctite® 4204 	<ul style="list-style-type: none"> • Hard-Anodized Aluminum • Silicon Carbide • 300-Series & 17-4 PH SS • 932 Bearing Bronze • Viton® • Samarium Cobalt • Loctite® 4204 	<ul style="list-style-type: none"> • Hastelloy® • Titanium • PEEK Plastic • Acetal • PTFE • Alumina • Zirconia • Buna Nitrile • EPDM
*For use w/ fuels, light oils, and hydraulic fluids	*For use w/ water and mildly corrosive solutions	

INTERFACE	-O/-W: 6mm Push-to-Connect Fittings (M6 Ports)
	-H: 1/8" Compression Fittings (NPT Ports)
	Custom Options: Barbed, Compression, AN Fittings (5/16-24 Ports w/ O-Ring Boss Seal per AS5202-02), Custom Covers (manifold-mount, alternate port type or orientation, integrated valves etc.)

Additional custom configurations/materials can be provided upon request (ex. welding, custom wiring, alternate seals, etc.)

DIMENSIONS (mm) & WIRING

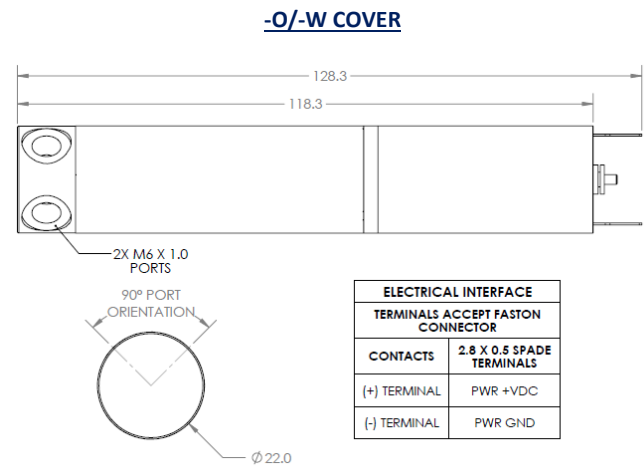

-H COVER (adds approx. 10mm to length)

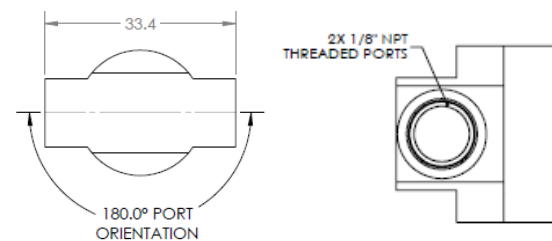

Refer to the Pump User Guide and/or Control Instructions manuals for important information on mounting and control setup.

SEE PAGE 3 FOR PERFORMANCE DATA

COMMON ACCESSORIES (Contact Flight Works to Purchase)

FLOW SYSTEM ITEMS

- Filters
- Fittings: Tee/Elbow/Y/Adapters
- Valves: Ball/Check/Needle

CONTROL COMPONENTS

- Speed Controllers
- Pressure Gauges/Regulators

TUBING

- Polyurethane Tubing: 3, 4, 6mm
- Tygon Tubing: Medium, Large
- Stainless Steel Tubing: 1/16", 1/8"

Water (≈ 1 cP)

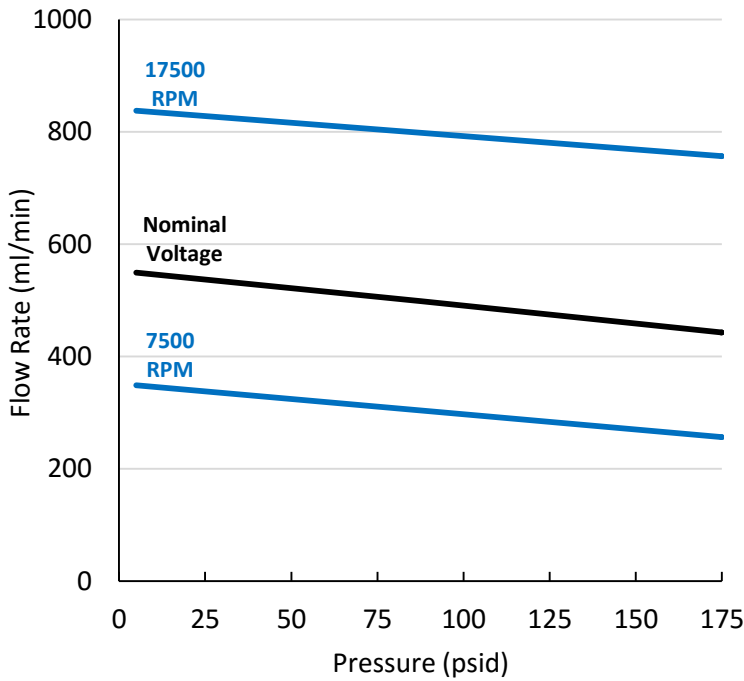

Heavy Fuel (≈ 2 cP)

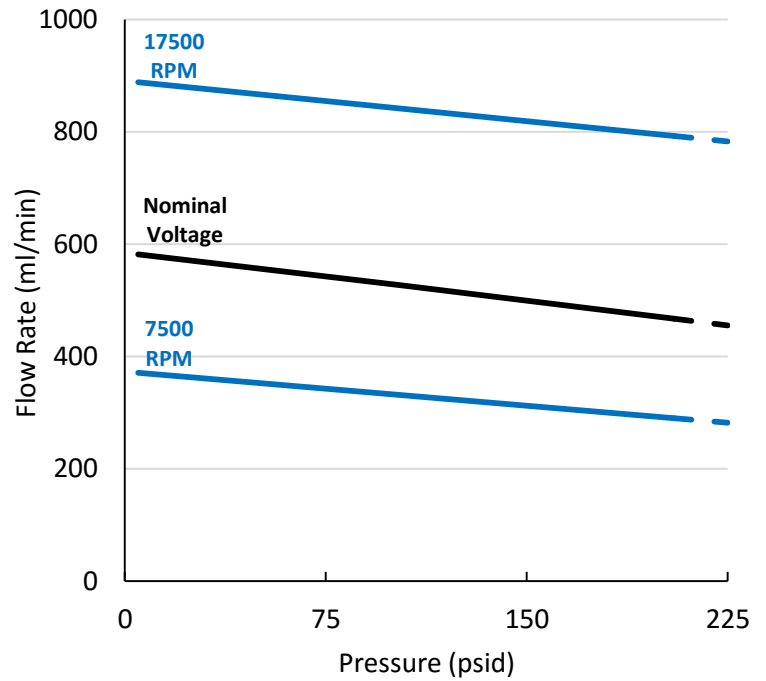

	Nominal Voltage	Speed Constant	Max Continuous Current
C49	12 V	981 RPM/V	3.21 A
C50	24 V	416 RPM/V	1.40 A
C51	48 V	211 RPM/V	0.69 A

NOTES: Dashed lines indicate intermittent operation; speed constant may vary at higher pressures;
RPM flow lines indicate performance at typical maximum and minimum speeds;

Ethylene Glycol (≈ 16 cP)

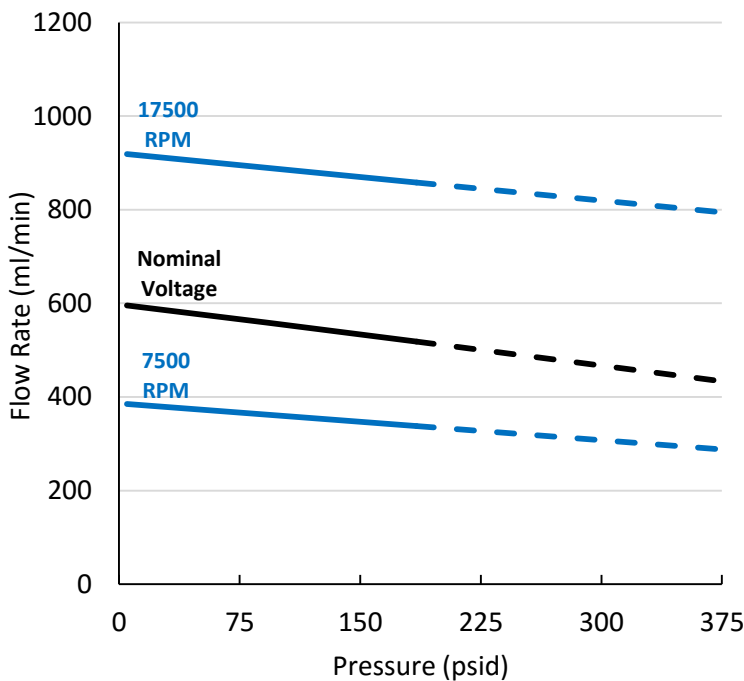

Hydraulic Oil (≈ 70 cP)

